



Flanged Patio Door Installation

LINCOLN WOOD PRODUCTS, INC.

These installation instructions are to be used when installing Aluminum Clad Sliding and Swing Patio Doors.

This instruction provides the minimum recommended procedures to correctly prepare the rough opening, install a flanged patio door unit and apply flashing within a residential or light commercial structure that has the weather resistant barrier applied. Local climate may dictate additional flashing at the discretion of the installer. These instructions are minimal recommendations only and do not supersede local building codes

CAUTION: If installing patio door into an older home, lead-based paint may be present. To minimize the exposure to possible lead-based paint during the removal of the existing patio doors, please consult www.epa.gov/lead for recommendations.

Please follow recommended local guidelines to properly recycle and/or dispose of all product packaging and construction/renovation waste.

Proper installation and maintenance of Lincoln patio doors are essential to proper door performance. Failure to follow these installation and flashing guidelines may void Lincoln's Limited Warranty. Lincoln recommends installation of its product by experienced contractor personnel. If you have questions regarding window installation, contact your Lincoln dealer, an experienced contractor or contact Lincoln at (800) 967-2461.

TOOLS/HARDWARE REQUIRED:

- Safety Glasses
- Hearing Protection
- Tape Measure
- Level
- Putty Knife
- Sealant & Caulk Gun
- 1/4" Shims
- Flashing Tape
- Backer Rod
- Insulation/Foam Sealant
- Hammer
- 1" Stainless or Galvanized Nails

Preparing the Rough Opening (R.O.)

CLEARANCE: Lincoln Wood Products Inc. published rough openings allow for a 1/4" of clearance on all sides of the unit for insulation purposes. Doors must be set on level sills. If sills are not level the use of rot proof shims to level sills are recommended. Sills that sag or hump up will affect the operation and performance of your Lincoln doors. It is the installer's responsibility to ensure that doors are installed plumb, level, and square.

NOTE: Unit must be installed square, plumb and level or warranty may be void.

MEASURING FOR SQUARE: Take measurements from bottom left corner to top right corner and bottom right corner to top left corner and compare. If measurements are equal the R.O. is square. If measurements are not equal, R.O. is out of square and it is then the responsibility of the installer to remedy this problem prior to installation (fig.1).

CHECKING FOR PLUMB: Place a level on both sides of the R.O. making sure the vertical measurement of each side is true. If R.O. is not plumb, it is then the responsibility of the installer to remedy this problem prior to installation (fig.1).

CHECKING LEVEL: Place a level on the sill of the R.O. making sure the horizontal measurement on the sill is level. If opening is not level, the use of rot proof shims may be used to level the sill. Be sure to support the entire sill to prevent the sill from sagging (fig.1).

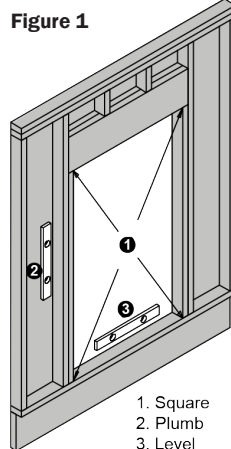

Preparing the Weather Resistant Barrier

Draw an "I-Cut" with a marker on the weather resistant barrier. Start from the top left of the R.O. and continue to the top right of the R.O. making sure mark is flush

with rough opening. Repeat process on the sill of the rough opening. From the middle of the top of the R.O. drop a line vertically so that it intersects with the sill R.O. (fig.2).

Using a utility knife, cut the lines in the weather resistant barrier starting with the head and working your way down to create the "I-Cut". Fold the side flaps over and into the interior side of the rough opening. Using staples every 12" to 16" fasten the flaps to the interior and trim excess (fig.3).

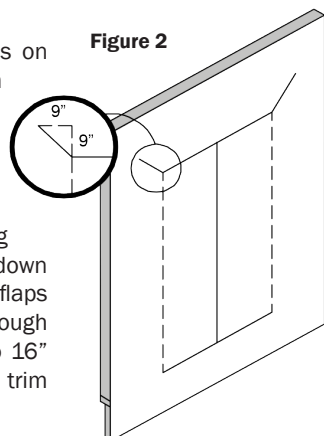

Per ASTM standards Lincoln Wood Products Inc. recommends a minimum of 9" wide flexible flashing. For that reason, measure 9" up and 9" over from the top left corner of your rough opening and mark. Repeat on top right corner. A scrap piece of flashing 9" x 9" may be used

to simplify this step. Once marked cut the weather barrier diagonally from the top corners of the rough opening to the mark made previously (fig.2). Fold weather barrier up and tape or tack temporarily out of way (fig.3).

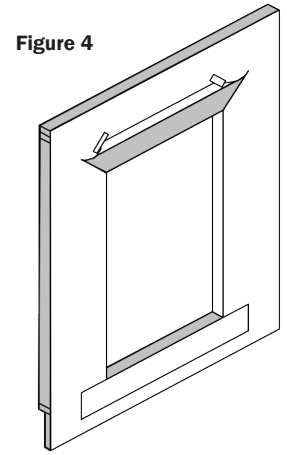
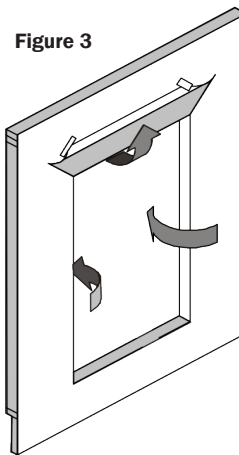

SILL FLASHING: Flashing can be flexible or adhesive back flexible. All flashing must be at least 9" wide & meet (ASTM D-779; water resistance of at least 24+ hours).

Cut sill flashing length 9" beyond each side of the R.O. (R.O. + 18") Apply sill flashing level with top edge of R.O. allowing 9" of flashing to extend to each side of R.O. (fig.4). In some installations, this step will not be possible i.e., doors on concrete slabs or at grade.

If using non-adhesive flashing, fasten the top and sides of the sill flashing with staples located 12" to 16" apart.

Sill Pan Flashing Installation

Lincoln Wood Products, Inc. requires the use of sill pan flashing under all Lincoln door products. The sill pan flashing should be used in conjunction with flexible flashing per Lincoln's instructions. Failure to comply with these recommendations may void Lincoln's Limited Warranty.

The sill pan flashing is to be the exact size of the sill R.O. with an up turned leg height of 1" on the sides and back of the sill pan. The intersection between the sides and back of the up turned leg must be sealed in a watertight fashion. The front edge of the sill pan should be down turned to seat against the framing material. In some installations, a down turned leg on sill pan will not be necessary.

Before installing sill pan flashing, determine if sill condition is level. If sill is not level, shims are required to level sill. Be sure to support the entire sill and not allow it to sag. The installer is responsible to install the door level. Rot proof shims are recommended for under sill applications.

Apply two continuous beads of sealant to the rough sill. One on the interior edge the second on the exterior edge. Both are to continue 6" up the R.O. on each side jamb (fig.5). If a shim is necessary place a shim into sealant and apply sealant over the top of the shim. This will ensure water will not penetrate under or over the shim (fig.5).

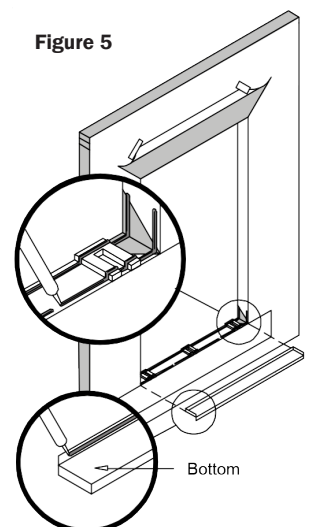

Pre-drill the sill pan at a maximum of 16" between fasteners before it is set into position, and apply a bead of sealant to the back side of the down-turned leg on the front edge of the sill pan to insure a water tight seal to framing material (fig.5).

Place sill pan into position, compressing it down into sealant and over any flexible flashing materials (fig.6).

Check sill pan for level before final installation. Apply sealant to the predrilled holes, attach fasteners, and apply sealant over the fastener head (fig.6). Place a bead of sealant on the interior side of the upturned leg on the inside edge of the sill pan. This will seal the inside edge of the doorsill to the sill pan and not allow any water or air to penetrate to the interior. A second bead of sealant is to be applied in a discontinuous bead on the exterior edge of the sill pan. Allow gaps of 1" to 2" in the sealant every 15" to 18". Continue both beads up the sill pan end cap to ensure sealing between the sill pan and side jamb.

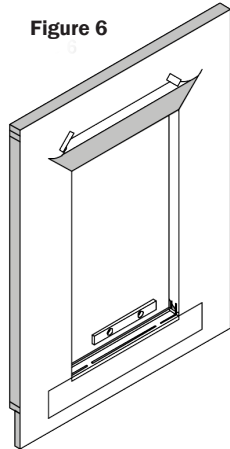

Figure 6

Door Installation

Before installation check door to make sure unit is complete and without defects. Corner gussets should be placed at the nailing fin corners of units. After corner gussets are in place, use sealant on any gap that may exist between the gusset and unit to make a weather tight seal. Do not install unit if corner gussets are missing. Contact your Lincoln dealer for replacements.

Apply a continuous bead of sealant, approximately 3/8" in diameter, to the back of the mounting flange and in line with the mounting holes. Alternatively, sealant can also be applied to the R.O. to line up with the holes on the mounting flange.

Place door into opening, press tight to building and check for square, level, and plumb (fig.7). **The installer is responsible to install doors square, level & plumb. Failure to do so may negate Lincoln's Limited Warranty.**

At either the left or right-side corner, tack door through one mounting hole. This will provide you with the ability to adjust the unit while keeping the door in place (fig.8). Lincoln Wood Products Inc. recommends the use of fasteners that penetrate door framing a minimum of 1". Stainless or galvanized nails or screws may be used. However, Lincoln Wood Products Inc. does not recommend the use of pneumatic nail guns and will not be responsible for any damage caused by the use of these nail guns.

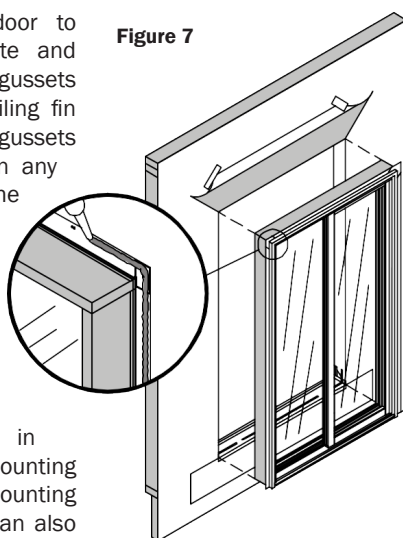

Figure 7

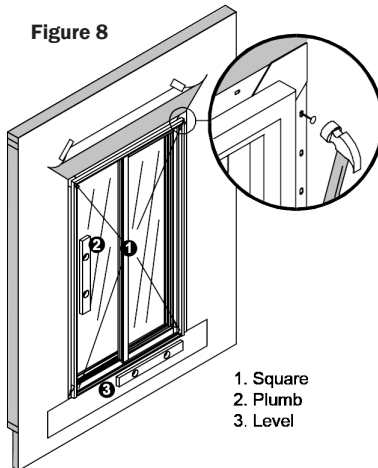

Figure 8

1. Square
2. Plumb
3. Level

Check unit for square and plumb, making adjustments using shims until door is square and plumb in the opening.

NOTE: Unit must be installed square, plumb and level or warranty may be void.

Tack opposite diagonal corner from first tack and check for level, plumb, and square. Fasten sides, top, and bottom, using every other mounting hole and continually checking unit for square, plumb, and level.

Jamb Flashing: Flashing can be flexible or adhesive back flexible. All flashing must be at least 9" wide and cut so length will extend 8- 1/2" beyond the head and sill on both sides of R.O. (R.O. + 17"). If stapling flashing do not penetrate through door mounting flange.

Apply a continuous vertical bead of sealant to the exterior portion of the vertical mounting flange, covering the mounting holes as you go. Continue bead 8- 1/2" above the R.O. (fig.9).

Install jamb flashing over side mounting flange and sealant bead, tight against window unit. If using a non-adhesive flashing staple, be sure not to staple through door mounting flange. Top edge of jamb flashing should extend a maximum of 8-1/2" above the R.O. The bottom of the jamb flashing extends 8-1/2" past the bottom of the R.O. overlapping the sill flashing applied earlier (fig.9).

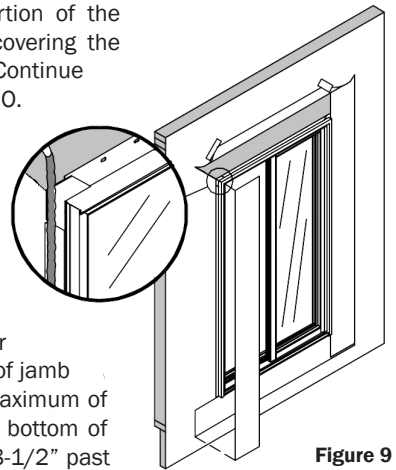

Figure 9

Head Flashing: Flashing can be flexible or adhesive back flexible. All flashing must be a minimum of 9" wide and cut so length is approximately 10" beyond the sides of the R.O. (R.O. + 20") This will allow the head flashing to overlap the jamb flashing applied earlier.

Apply a continuous horizontal bead of sealant to the exterior portion of the horizontal mounting flange at the head, covering the mounting holes as you go, but not extending past the vertical mounting flange (fig. 10).

Install head flashing over the horizontal mounting flange and fasten. If using a non-adhesive flashing staple, being sure not to penetrate through door mounting flange (fig.11).

Lower the head weather resistant barrier flap previously taped out of way (fig.11). Place over the head flashing. Apply sheathing tape to seal diagonal cut made in weather barrier.

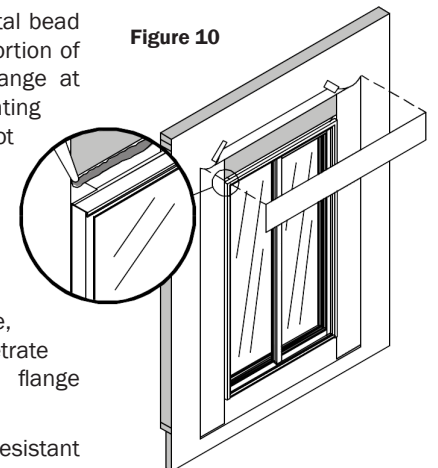

Figure 10

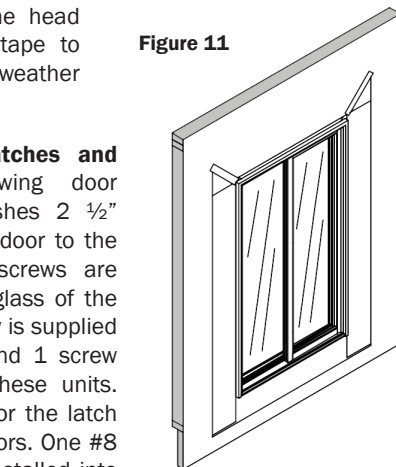

Figure 11

Shims & Screws for Latches and Hinges: For certain swing door applications Lincoln furnishes 2 1/2" long screws to secure the door to the framing material. These screws are bagged and taped to the glass of the door. One #10 x 2 1/2" screw is supplied for each hinge. You will find 1 screw missing from hinges on these units. Screws are also supplied for the latch strikes on certain swing doors. One #8 x 2 1/2" screw should be installed into each latch strike plate. Insert shims to ensure jamb is plumb at screw locations and insert screw into strike latch or hinge and through shim material. If R.O. is correct screw will reach framing material. These steps must be followed to achieve structural performance per the products DP rating.

On slide doors the latch jamb should be shimmed at top bottom & center to ensure jamb is plumb. Fasteners should be installed at these locations through the jamb, shims and into the framing material. Longer screws can be inserted through the latch keeper into the framing lumber for security reasons. **Note:** these screws are not supplied.

This completes your door installation.
Failure to follow these recommended instructions may void Lincoln's Limited Warranty